

TireHand® **TH2551B**

Technical Specifications

Tire Manipulator



An Oshkosh Truck Corporation Company

TireHand® 2551B

Specifications

Tire Size Capacity	18.00-25 – 50/65x51
Max. Capacity	10,000 lb (4536 kg)
Clamping Span	52 – 135" (132.1 – 342.9 cm)
Method of Clamping	Parallelogram
Clamping Pad Rotation	360° (6.28 rad) continuous
Body Rotation	350° (6.11 rad)
Side Shift	
Standard on loader,	12" (30.5 cm) lateral movement
optional on forklift	
Clamping Load Holding Valves	
On clamping side	Counterbalance valve
Hydraulic Controls	
Manual lever	Control valve on carrier vehicle
Electric switch	Control valve on TireHand body
Rotation System	Spur gear drive
Weight	8640 lb (3520 kg)
Optimum Pump Capacity	12 gpm @ 2500 psi (45.4 L/min @ 172.4 bar)
Counterweight Needed	As required for stabilization
Horizontal Center of Gravity	
From vehicle attachment point	38" (96.5 cm)
With 36 – 51 tire	96" (243.8 cm)

Manufacturer's Limited Warranty Coverage

Products manufactured by IMT are warranted to be free from defects in material and workmanship under proper use, application, and maintenance in accordance with IMT written recommendations, instructions, and specifications as follows:

1. 90 days labor on IMT workmanship from the date of shipment to the end user.
2. One year on original IMT parts from the date of shipment to the end user.

Geometric Configurations

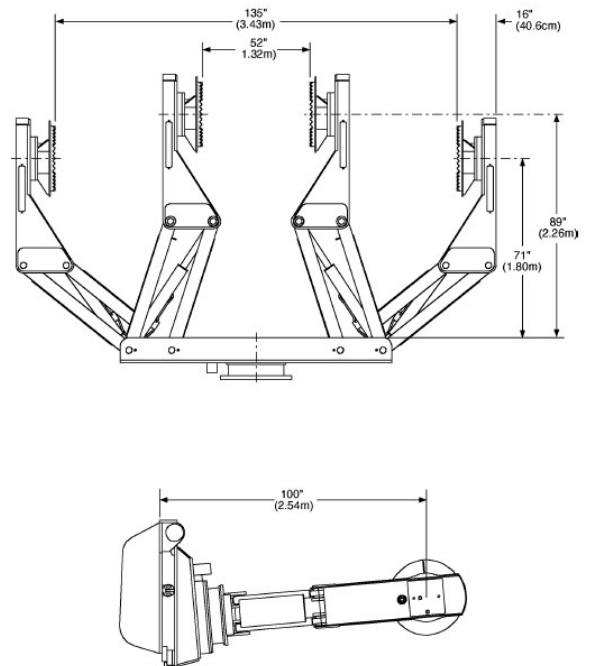

Vehicle Compatibility

The TireHand 2551B will permanently attach to either a forklift truck or a front-end loader. When mounting to a forklift truck, we recommend equipping the truck with a side-shifter. If used with a front-end loader, quick couplers should be used to enable the TireHand to be disconnected, so the original bucket can be attached quickly to the machine for normal operations.

Note: Where applicable, specifications are in accordance with SAE standards.



An Oshkosh Truck Corporation Company

Iowa Mold Tooling Co., Inc.

500 Highway 18 West • P.O. Box 189 • Garner, Iowa 50438-0189
641-923-3711 • Fax: 641-923-6063 • www.imt.com

800-247-5958

IMT reserves the right to make changes in engineering, design, and specifications; add improvements; or discontinue manufacturing at any time without notice or obligation.

IMT, IMT LOGO, and TIREHAND are registered trademarks or trademarks of Iowa Mold Tooling Co., Inc., Garner, IA, USA.

© 2007 Iowa Mold Tooling Co., Inc. All Rights Reserved.