

Mechanics Truck DOMINATOR® PROPANE BODY

Technical Specifications

Commercial Vehicles



Specification	12 ft
Body Rating	38,000 ft-lb (5.3 tm)
Body Weight	3700 lb (1678.3 kg)
Body Width (including rain eaves)	96" (244 cm)
Sidepack Height	44" (112 cm)
Sidepack Depth	22" (56 cm)
Cargo Deck Width	71.5" (182 cm)
Step Bumper Depth	12" (30.5 cm)
Tailgate Height	12" (30.5 cm)
Total Storage Capacity	76.2 cu ft (2.2 m ³)
Angle of Departure	10° (0.17 rad)
Compartment Dimensions	
LH 1st Vertical	29.5"W x 38.5"H (78 cm x 98 cm)
LH 2nd Vertical	16.5"W x 38.5"H (42 cm x 98 cm)
LH 1st Horizontal	63.38"W x 21"H (161 cm x 53.3 cm)
LH Rear	18"W x 38.5"H (45.7 cm x 98 cm)
RH Front Underbody Toolbox	40"W x 16.5"H (102 cm x 42 cm)
RH Rear	30"W x 19.5"H (76 cm x 49.5 cm)



An Oshkosh Corporation Company

Dominator® Propane Body Mechanics Truck



Tank Hauling Capacity

The propane body is designed to transport one 500-gallon (1892.7 L) propane tank or up to 13 100-pound (45.4 kg) propane cylinders.

Body Materials

The sidepacks are constructed of 10-gauge and 12-gauge galvanized steel. The floor structure is constructed of 12-gauge galvanized and 1/8" (0.32 cm) deckplate steel. The workbench is constructed of galvanized and cold-rolled steel.

Body Substructure

The body substructure includes 12-gauge galvanized material with integral crane box, front outrigger receptacles and rear outrigger housing.

Aluminum Side Panels

The side racks are constructed from 0.12" (.304 cm) thick aluminum for ease of handling and corrosion resistance.

Electrical System

The electrical system consists of a central power distribution point in the crane box using automotive-style harnesses. The circuits use white wire with the circuit function printed every 3" (7.6 cm). The harness is protected by an overbraid that is heat- and cut-resistant.

Doors

The doors are constructed of 14-gauge galvanized steel with internal formed eaves and hemmed edges. The latches are a 3-point, locking rotary T-handle style. They are constructed of cast steel with a powdercoat finish. The hinges are stainless steel with composite washers.

Options

- Drawers and drawer sets
- Standard adjustable shelves
- 3"H (7.6 cm) divided adjustable shelves
- Outrigger — manual and hydraulic
- Individual incandescent compartment lights
- Work lights
- Telescopic cranes up to 38,000 ft-lb (5.3 tm)

Storage Capacity

Total body capacity 76.2 cu ft (2.2 m³)

Chassis

Dominator Propane Body Single Axle (CA)
12' Body 84" (213 cm)

Minimum cab-to-axle dimensions (cab-to-trunnion for tandem axle)

Substructure

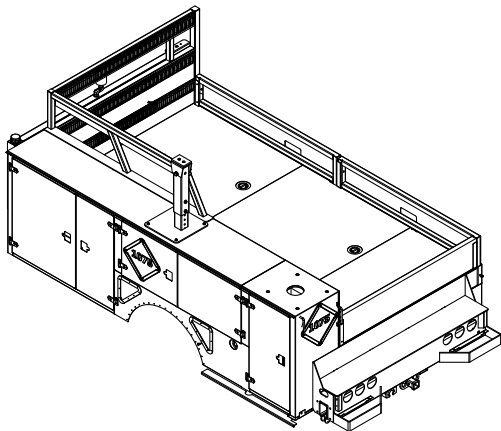

Angle of Departure

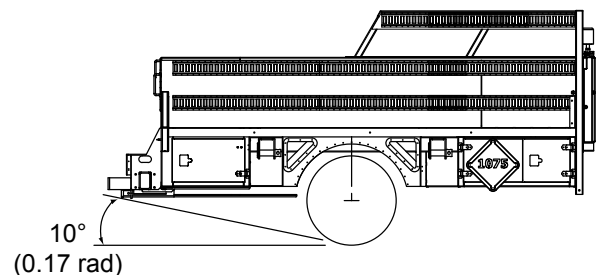

Iowa Mold Tooling Co., Inc.

500 Highway 18 West • P.O. Box 189 • Garner, Iowa 50438-0189
641-923-3711 • Fax: 641-923-6063 • www.imt.com

800-247-5958

IMT reserves the right to make changes in engineering, design, and specifications; add improvements; or discontinue manufacturing at any time without notice or obligation.

IMT and the IMT logo are registered trademarks or trademarks of Iowa Mold Tooling Co., Inc., Garner, IA, USA.

© 2009 Iowa Mold Tooling Co., Inc. All Rights Reserved.